



Architectural  
Ceiling Company

METAL CEILING

LUXURY CEILING

METAL LOUVRE

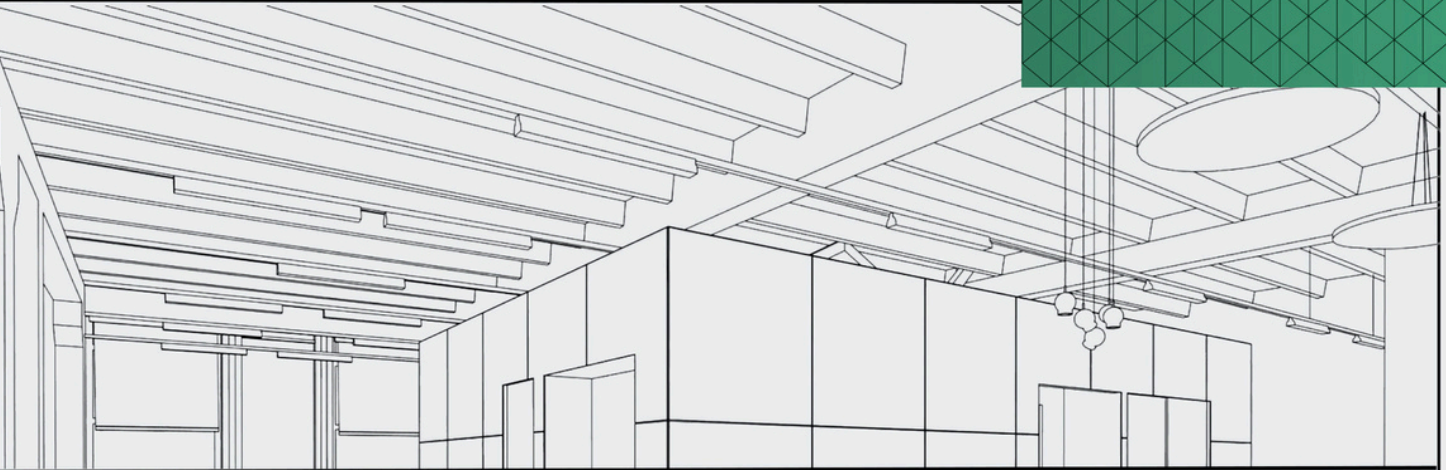
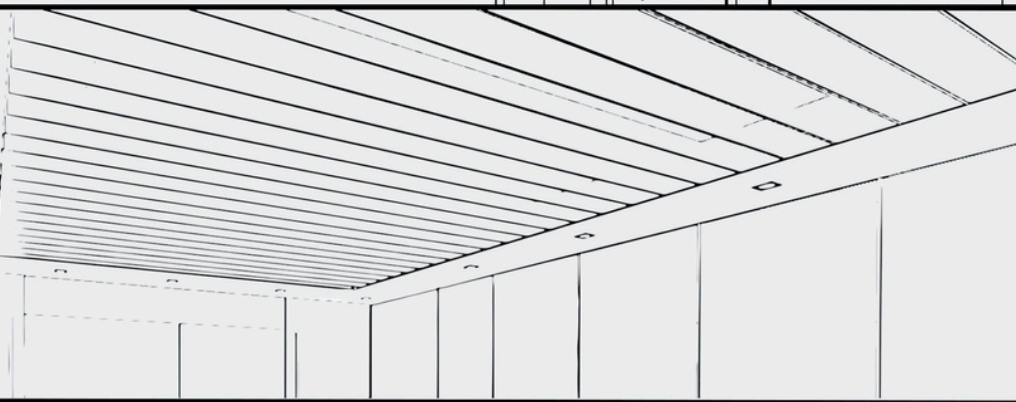
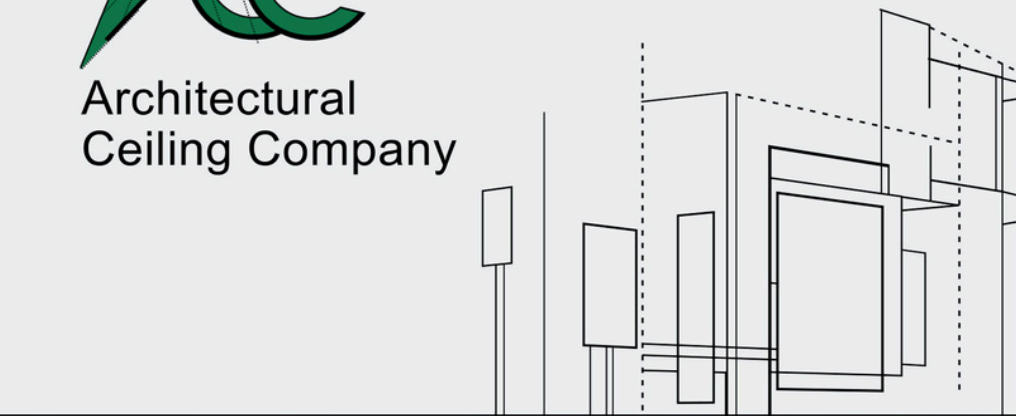

# About Us

## Welcome to Architectural Ceiling Company

Metal is versatile, fluid and can be moulded into infinite possibilities. For us, Ceilings and Facades provide a canvas to every space - they don't just add personality & finesse but also create a safe heaven.

We understand Metal Ceilings and facades in every form and push boundaries to help bring an artist's vision to life.

We believe in creating bespoke Ceilings and Facades that are functional, backed by industry expertise and manufactured at a best-in-class facility.

## Our Expertise

Architects, Builders, Developers, & Designers persistently push boundaries to transform their ground-breaking ideas and renderings to life.

Architectural Ceiling Company steps in to fill in the blanks, bridging the void between customized design and traditional manufacturing, to nurture a new level of comprehensive caliber.

Customer satisfaction is our primary intent. With spick-and-span assured excellence, our methods keep your approved design within budget and on schedule. Our in-house creative team strive to arrive at solutions that fit the project requirements and provide systems and products with guaranteed long life and performance.

We hold every designer/architect's idea and concept with tangible intent. At the same time, our team ripens the most essential parameters by delivering options on modifying to achieve a detailed design aesthetic, the budget, standard acoustic rating and for project-specific conditions.

Most of our solutions are centered on speedy installations. Shorter Time Leads to Lower Overall Cost.

# 300C LINEAR CEILING

## 300C WIDE PANEL SERIES ISOMETRIC

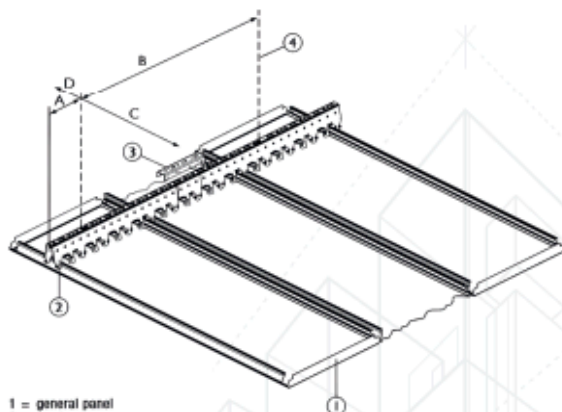

- 1 = general panel
- 2 = carrier
- 3 = carrier splice
- 4 = hanger

Note: Carriers Are Directional. Please Check Orientation Prior to Installation of Carriers



### Material:

Galvanized Steel 0.5mm, Aluminium 0.65mm

### Panels:

Choose from high-quality 0.5mm thick galvanized steel or 0.5mm thick coil coated GI sheets with a bevel edge for a clean finish. Panels are available in lengths up to 5 meters.

Our 300C Linear Ceiling system empowers architects and designers with a sophisticated solution for creating modern, high-performing ceilings. These long-lasting panels, available in lengths up to 5 meters, seamlessly blend clean aesthetics with essential qualities like corrosion resistance and washability. The pre-finished, easy-to-maintain system offers a cost-effective option for a variety of applications, from office spaces to commercial buildings.

### Carrier:

The panels are securely clipped into a powder coated GI carrier (0.5mm thick, 41.5mm wide, 62mm deep) with cut-outs to hold the panels in a 300mm module at 1.2-meter intervals.

### Paint Finish:

60 microns thick powder coating on exposed surface or 25 microns polyester coil coated over primer on visible surface with primer coat on rear side.

### Suspension:

The carrier system is suspended by a 4mm diameter GI rod and a stainless steel suspension spring clip at a distance of 1.2 meters center-to-center.

# OUR VISION

“ Building With Excellence  
Serving With Integrity ”

# WHY METAL?

As a ceiling fabricator, we are often asked why we concentrate on metal as Ceiling & Louvre. The answer is simple

1. Steel & Aluminum are two of the most sustainable materials used in construction.
2. Metal is high quality material offering improved aesthetic through design flexibility
3. Highly durable and robust, metal maintains its appearances long after other materials need replacing
4. Long term, metal is far more cost effective than alternative materials

# CONTACT US



Architectural  
Ceiling Company

METAL CEILING | LOUVRE | LUXURY CEILING

Parekh House | 2nd Floor | 161 Lenin Sarani Kolkata 700013

Ph: +91 9073705478 | +91 9748418762

Email : [sales@theceiling.in](mailto:sales@theceiling.in) | [www.theceiling.in](http://www.theceiling.in)